



EROGATORI SOPRABANCO
TOP COUNTER DISPENSER

25 l/h
EASY
WATER
TOP

SW



CA



mm

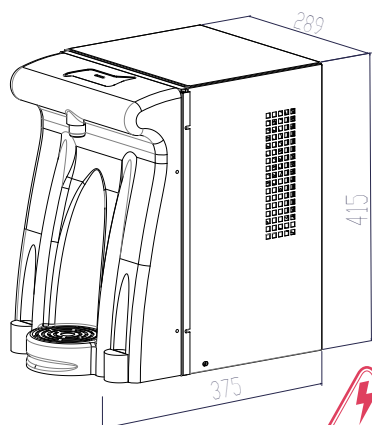

- **EROGATORE SOPRABANCO A 2 O 3 SELEZIONI PER ACQUA NATURALE A TEMPERATURA AMBIENTE, ACQUA NATURALE REFRIGERATA, ACQUA GASSATA REFRIGERATA**
- **SISTEMA DI REFRIGERAZIONE A BANCO GHIACCIO**
- **CARENATURA ESTERNA IN SKIN PLATE GRIGIO E FRONTALE IN MATERIALE PLASTICO TERMOFORMATO DISPONIBILE IN 5 DIVERSI COLORI**

1 pcs x 22kg

15 pcs x 1 pallet

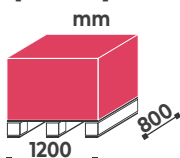
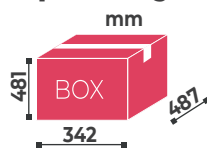

- **COUNTER TOP WATER DISPENSER WITH 2 OR 3 SELECTIONS: ROOM TEMPERATURE, COLD AND COLD SPARKLING WATER**
- **ICE BANK SYSTEM**
- **GREY EXTERNAL HOUSING WITH THERMOFORMED FRONT AVAILABLE IN 5 DIFFERENT COLOURS**

CODICE CODE	DESCRIZIONE DESCRIPTION	SISTEMA DI RAFFREDDAMENTO COOLING SYSTEM	POTENZA COMPRESSORE COMPRESSOR POWER	CAPACITÀ VASCA WATER TANK CAPACITY	CAPACITÀ EROGAZIONE DISPENSING CAPABILITY	POMPA DI CARBONAZIONE CARBONATION PUMP	VOLUME GASATORE CARBONATOR CAPACITY	CONNESSIONI CONNECTIONS	RICIRCOLO RICIRCULATION	€
			hp	l	l/h		l	In/Out		
BS11122*	EASY WATER TOP CA	Banco ghiaccio Bank cooling	1/8	3	25	-	-	H ₂ O IN 8mm	-	
BS11120*	EASY WATER TOP SW PB	Banco ghiaccio Bank cooling	1/8	3	25	Booster 80l/h	0,5	CO ₂ IN 6mm H ₂ O IN 8mm	-	
BS11121*	EASY WATER TOP SW PV	Banco ghiaccio Bank cooling	1/8	3	25	Volumetrica Volumetric 120l/h	0,5	CO ₂ IN 6mm H ₂ O IN 8mm	-	

* 1 2 3 4 5

