

**EROGATORI SOTTOLAVELLO
UNDER-SINK DISPENSER**



18 l/h

**MINI
OSMOGAS
FRESH DRY
UNDER**

✓ **Membrana integrata**
Integrated membrane

✓ **Erogatore sottobanco largo solo 17 cm**
Under counter dispenser only 17 cm wide

SW



mm

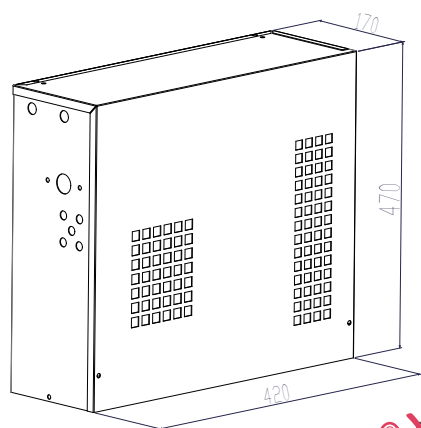

Optional



- **EROGATORE SOTTO BANCO CON SISTEMA DI FILTRAZIONE AD OSMOSI INVERSA A PRODUZIONE DIRETTA, CHE EROGA ACQUA OSMOTIZZATA A TEMPERATURA AMBIENTE, FREDDA NATURALE E FREDDA GASSATA**
- **LE DIMENSIONI SONO PARTICOLARMENTE CONTENUTE IN MODO DA POSIZIONARLA ANCHE IN PICCOLI VANI**
- **IL SISTEMA DI RAFFREDDAMENTO È A SECCO CON BLOCCO D'ALLUMINIO**
- **CARENATURA IN SKIN PLATE BIANCA**
- **L'USO DI UNA MEMBRANA DA 400 GALLONI GARANTISCE UN'ELEVATA PRODUZIONE DI ACQUA OSMOTIZZATA**

- **UNDER COUNTER DISPENSER WITH FILTRATION SYSTEM THAT USES A DIRECT REVERSE OSMOSIS TECHNOLOGY, PROVIDING OSMOTIC WATER AT ROOM TEMPERATURE, COLD STILL WATER AND COLD SPARKLING WATER**
- **THE SMALL DIMENSIONS ALLOW FOR THIS SYSTEM TO BE PLACED ALSO WHERE SPACE IS CONSTRAINED**
- **DRY COOLING SYSTEM WITH ALUMINUM BLOCK**
- **WHITE EXTERNAL HOUSING**
- **THE USE OF A 400 GALLON MEMBRANE GUARANTEES A HIGH PRODUCTION OF OSMOTIC WATER**

1 pcs x 27kg

18 pcs x 1 pallet

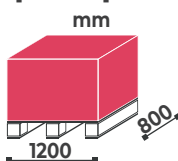
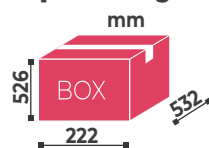

**CODICE
CODE**

**DESCRIZIONE
DESCRIPTION**

OI20096

**MINI OSMOGAS
FRESH DRY
UNDER**

SISTEMA DI RAFFREDDAMENTO COOLING SYSTEM	POTENZA COMPRESSORE COMPRESSOR POWER	CAPACITÀ VASCA WATER TANK CAPACITY	CAPACITÀ EROGAZIONE DISPENSING CAPABILITY	POMPA DI CARBONAZIONE CARBONATION PUMP	VOLUME GASATORE CARBONATOR CAPACITY	CONNESSIONI CONNECTIONS	RICIRCOLO RICIRCULATION	€
	hp	l	l/h		l	In/Out		
A secco Dry	1/10	-	18	Volumetric Volumetric 300l/h	0,5	CO ₂ IN 6mm H ₂ O IN 3/4" M H ₂ O OUT 6mm	-	