

**EROGATORI SOPRABANCO  
TOP COUNTER DISPENSER**



**15 l/h  
QUEEN**

SW



mm

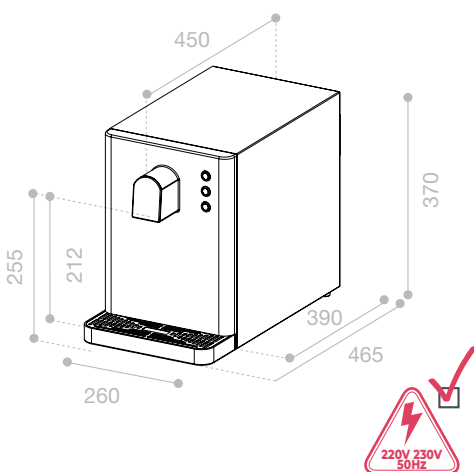

**1 pcs x 28kg**

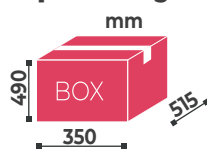

**15 pcs x 1 pallet**

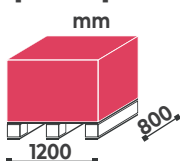

- **EROGATORE SOPRABANCO A 2 O 3 SELEZIONI PER ACQUA A TEMPERATURA AMBIENTE, ACQUA REFRIGERATA, ACQUA GASSATA REFRIGERATA**
- **SISTEMA DI REFRIGERAZIONE A SECCO**
- **CARENATURA ESTERNA IN ZN EPOXY**

- **COUNTER TOP WATER DISPENSER WITH 2 OR 3 SELECTIONS: ROOM TEMPERATURE WATER, COLD AND COLD SPARKLING WATER**
- **DRY COOLING TECHNOLOGY**
- **ZN EPOXY HOUSING**

CODICE CODE	DESCRIZIONE DESCRIPTION	SISTEMA DI RAFFREDDAMENTO COOLING SYSTEM	POTENZA COMPRESSORE COMPRESSOR POWER	CAPACITÀ VASCA WATER TANK CAPACITY	CAPACITÀ EROGAZIONE DISPENSING CAPABILITY	POMPA DI CARBONAZIONE CARBONATION PUMP	VOLUME GASATORE CARBONATOR CAPACITY	CONNESSIONI CONNECTIONS	RICIRCOLO RICIRCULATION	€
			hp	l	l/h		l	In/Out		
<b>SS014588</b>	<b>QUEEN</b>	A secco Dry	1/10	-	15	Booster 100l/h	0,79	CO <sub>2</sub> IN 6mm H <sub>2</sub> O IN 6mm	-	